



# INSTALLATION

## DECKING

DaVinci Shake must be installed on a smooth flat surface (plywood or OSB); minimum 15/32" APA approved plywood or 7/16" approved OSB. It is necessary that all previous roofing materials be removed prior to installation of DaVinci Shake. Imperfections in the decking may transmit through to finished roof.

## DRIP-EDGE

Metal flashing is required on gable ends and eaves. An overhanging drip edge is recommended on gable ends to help mask the rib structure on the underside. An overhanging drip edge may also be used on eaves although non-overhanging drip edge styles are acceptable options.

## SELF-ADHERED MEMBRANE

(Severe Climate Underlayment in accordance with Chapter 15 of the UBC)

In areas where the average daily temperature in January is 25° F or lower or where ice buildup is possible, DaVinci requires self-adhered membrane be installed: from the bottom edge extending two feet above the exterior wall line on all eaves. The self-adhered membrane is required in all valleys regardless of average daily temperatures or the possibility of ice buildup.

## UNDERLAYMENT AND INTERLAYMENT

### Method 1: Class A installation

One layer of GAF VersaShield® Fire-Resistant Roof Deck Protection (ESR-2053) in addition to required self-adhered membrane.

### Method 2: Class A Installation

One layer Fontana VulcaSeal G40 in addition to required self-adhered membrane (This system is not recognized by ICC-ES).

### Method 3: Class C Installation

The entire roof must be covered with an approved underlayment in addition required self-adhered membrane.

**Pitches below 6:12** – DaVinci Shake should be installed with 30 lb felt interlay. Felt interlay is installed by rolling out 18" wide rolls of 30 lb felt at the same exposure as the shakes. The felt should be applied over the top portion of the shakes and extend onto the plywood sheathing so that the bottom edge of the felt is positioned at a distance above the butt equal to twice the weather exposure. So for an exposure of 10", start the layer of felt 20" above the butt line of the course below. If a class A installation is required the felt interlay must be used in addition to the other required underlayments. An alternative to using felt interlay is to use two layers of approved underlayment with their laps offset. If class A is required one of these layers may be GAF VersaShield or Fontana VulcaSeal G40.

**Note 1:** Underlayment and Asphalt Shingles are listed Class A components of a listed roof deck assembly by an Approved Agency. The third party program in which products are certified, carry a label, and are listed in the directory of an agency accredited by the International Accreditation Service, Inc. (IAS), or by an accredited body that is a partner with IAS in a mutual recognition arrangement, pertaining to certification bodies and their compliance with ISO/IEC Guide 65, General Requirements for Bodies Operating Product Certification Systems. These underlayment and asphalt shingle components are to meet Class A Classification when tested to ASTM E108 or UL 790.

**Note 2:** Underlayment and Asphalt Shingle components are to be installed with mechanical fasteners in accordance with the manufacturer's published installation instructions. Self-adhering or adhesive applied underlayment and asphalt shingle installations are outside the scope of this listing.

## FASTENERS

Tiles should be installed with nails long enough that they will penetrate through the roof deck by at least 3/16". In most instances, 1 3/4" roofing nails are acceptable. We recommend copper, stainless steel, or hot-dipped galvanized nails. Ring-shank nails should be used in high wind areas.

## STARTER COURSE

Each starter tile should be installed so that it extends past the drip edge by approximately 1". If using overhanging drip edge, the starter shingle may overhang less if it is appropriate for the gutter system. The starter tiles should be installed with the DaVinci logo on top. The starter tiles should be spaced 3/8" apart as tiles will expand when warm. Each starter tile should be nailed with two approved nails on a line approximately 6" from the butt and 3/4" from outside edge.

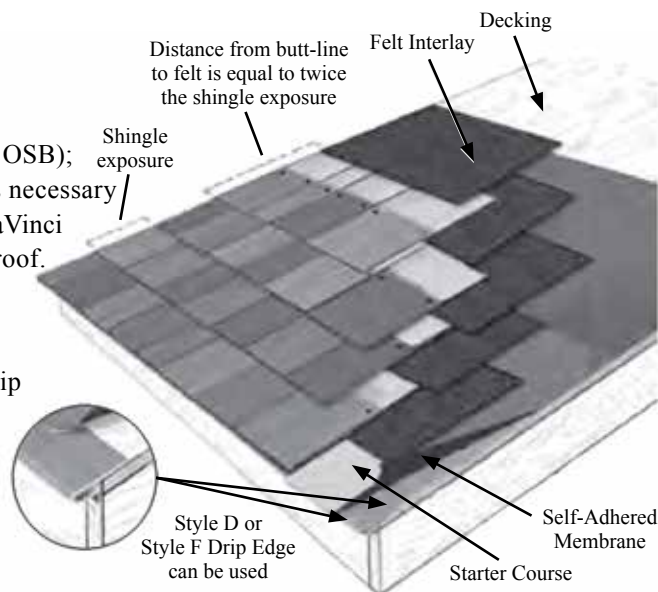

# INSTALLATION

## GETTING STARTED

Use approved nails in each shake at or near nailing location shown on the shakes (see page 10). Nails may be placed lower than the indicators as long as the tile above it covers the nail. Once the starter tiles are in place, begin installing shakes in the lower left corner (or lower right corner for a left-handed roofer). The shakes should be flush with the starter tiles on the outer (rakes) and lower (eaves) edges. DaVinci recommends a minimum 3/8" gap between shakes.

Two methods of installation are available:

1. Straight: in which the exposure of each shake is kept consistent
2. Staggered: in which the exposure varies by a maximum of 1" on adjacent shakes

Use the alignment indicator at the top of each shake to help manage the exposure. An exposure of between 9" or 10" is acceptable for straight courses and 9" for staggered courses. As you progress up the roof, be careful not to damage shakes already in place. Put something, perhaps a piece of cardboard or cut shake, under toe irons (scaffolding brackets) to avoid scratching or marring the shake already installed below.

## STRAIGHT COURSING

Install the shakes one at a time starting in the lower left hand corner if right handed or lower right hand corner if left handed. The first course of shakes should be laid directly on the starter tiles with the butt of the shake flush with the butt of the starter tile. The shakes should be installed individually with two nails in or near the defined areas. The shakes should be laid individually with a rack type system, also known as rack-style, stair-stepping, or pyramiding; to prevent same size shake directly on top of another. The shakes should be laid with an approximate 3/8" gap between each shake. The gaps between shakes on adjacent courses should offset by a minimum 1 1/2". To assure proper horizontal alignment we recommend that chalk lines be snapped frequently. These chalk lines should be placed on the underlayments so that the shakes are aligned by the tips of the tiles rather than the butts.

***Chalk lines should be snapped on underlayment with the tips of the shakes following the lines. Do not snap lines on DaVinci Shake or use red chalk as the chalk may permanently discolor the shake.***

**Straight Coursing on DaVinci Shake at a 10" Exposure**

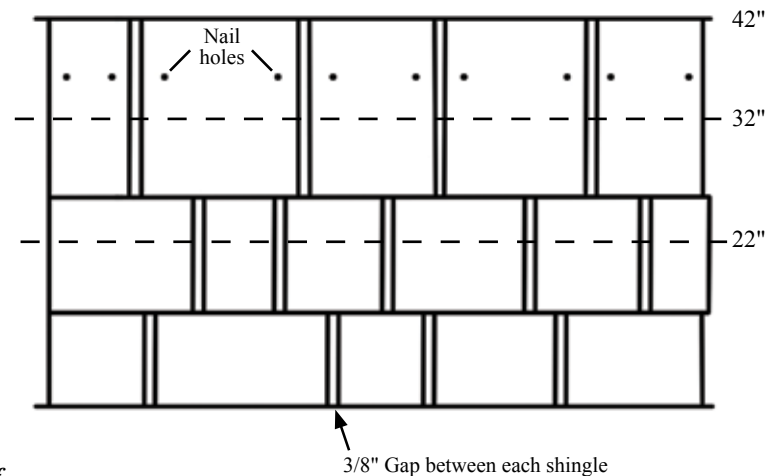

**Staggered Coursing on DaVinci Shake at a 9" Exposure**

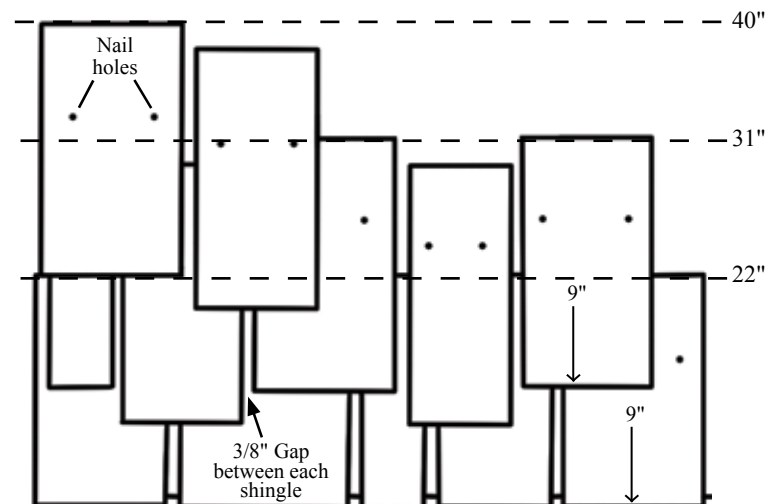

## STAGGERED COURSING

Staggering the courses is accomplished by laying the shakes in 9" courses with every other shingle lowered 1".

An example of how to accomplish this is as follows:

**Step 1:** Lay the first course of shakes flush on top of the starter. Then snap a horizontal line 9" above the tips of the shakes you just installed or 31" from the eave line (butt of the shake you just laid).

**Step 2:** The first shake on second course should be installed putting the tip of the shake on the chalk line. The next or adjacent shake should be 1" below the line. The third shake should be on the line; the fourth shake should be below the line. This continues in the same pattern all the way across the roof one shingle tip on the line and the next 1" below the line.

# INSTALLATION

## STAGGERED COURSING *(Continued)*

**Step 3:** Snap another horizontal line 9" above the line you chalked in Step 2 or 40" above the butt of the first course of shakes. Start laying shakes as in Step 2 with the first shake tip on the line and the next shake tip about 1" below the line.

**Step 4:** Continue up the roof in this manner. Every course does not need to be chalked. As roofers begin to understand the concept, they may use alignment indicators to accomplish the stagger. However, we do recommend frequent horizontal chalking to assure correct alignment.

*Chalk lines should be snapped on underlayment with the tips of the shakes following the lines. Do not snap lines on DaVinci Shake or use red chalk as the chalk may permanently discolor the shake.*

**Single-Width 9" Shake Installation Tip:** 4 ½" or 5" setback pattern

**Method 1:** A 5" setback pattern is recommended. In this method, starting from the bottom course, each 9" shake is set back 5" from the shake on the adjacent course. This pattern is most easily established by using a roofing hammer with gauge set at 5". Once the pattern has been established the setback should be checked occasionally.

**Method 2:** A 4 ½" pattern may also be used. In this method, starting from the bottom course, each 9" shake is set back 4 ½" from the shake on the adjacent course. This method requires that the pattern be straight vertically as well as horizontally because the breaks between shakes on alternate course are aligned. With this method we recommend frequent vertical chalk lines so that the pattern may be checked regularly.

## GAP

The recommended gap between shakes is 3/8" with a minimum 3/16" gap required. The number of shingles per square for DaVinci Shake is based on the assumption of 3/8" spacing between shakes. If spacing is less, more shingles per square will be required.

## AVOID "CRACK ON CRACK"

The gap between two shingles in one course should always line up 1½" or more from the gap between two shingles in the course below.

### Correct



### Incorrect

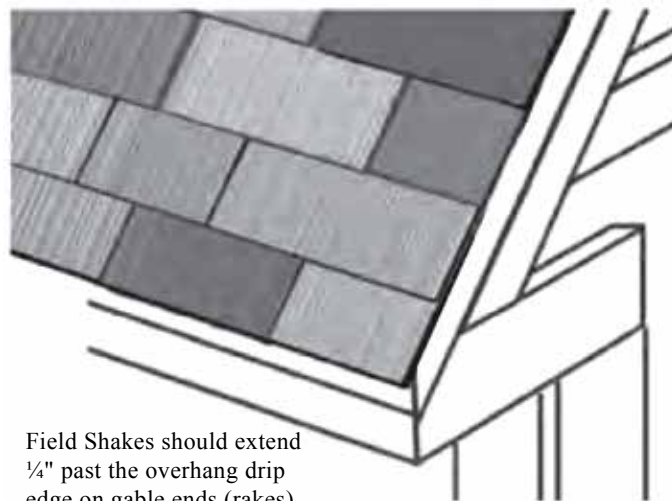

Field Shakes should extend ¼" past the overhang drip edge on gable ends (rakes).

## GABLE ENDS / RAKES

Cutting DaVinci Shakes at gable ends, or where a course terminates can almost always be avoided by choosing from the five different shake sizes and adjusting the spacing between shakes. In the rare case when cutting is required, shakes should be cut so that the factory edge faces out on the gable end.

### Single-Width Shake Installation Tip

The shakes are all 9" wide so must be cut at gable ends and any abutments. The 9" shakes should be cut so that the factory edge is on the outside.

## CUTTING

DaVinci Slate may be cut with a utility knife and straight edge. It may also be cut effectively with a circular saw. Carbide tooth blades are recommended for maximum blade life.



## COLOR AND WIDTH VARIATION

DaVinci multi-width field shakes come in five widths: 9", 8", 7", 6" and 4". Each bundle contains a mixture of 25 shakes and includes a pre-collated assortment of widths and colors needed for each color blend. Single-Width Valoré shakes come in a single 9" width with 20 shakes per bundle. DaVinci Roofscapes recommends that the shakes should generally be installed as they come out of the bundles. Keep in mind there must be 1½" side lap maintained and installation must be in a rack or pyramid style.

# INSTALLATION

## ONE-PIECE HIP AND RIDGE APPLICATION: HIP AND RIDGE PREPARATION

DaVinci one-piece hip and ridge shakes have an optimum appearance when used on pitches of 12:12 or less. Steeper pitches may cause outside edge to lift and it is recommended the conventional two-piece hip and ridge method be used for pitches greater than 12:12. Roofing nails that penetrate through the roof deck and exceed it by 3/16" should be used.

## RIDGE VENT APPLICATION

If using a continuous ridge vent we recommend a rigid shingle roll-over type. Once the continuous vent is installed, prepackaged 12" DaVinci One-Piece Hip and Ridge shingles should be installed in accordance with the standard hip and ridge installation instructions below. Special caution should be used when cutting the decking on the ridge to assure adequate nailing for the ridge pieces.

## DAVINCI ONE-PIECE HIP AND RIDGE SHINGLE INSTALLATION

- DaVinci Shake one-piece hip and ridge should be installed at a 10" exposure with two roofing nails in each piece.
- A pair of 6" shakes should be used as a starter course underneath the first piece of hip and ridge. These 6" tiles should be cut so that they are approximately 5" widths and they should also be cut in length so that they don't extend beyond the top of the second course of field tiles. If preferred on the bottom of a hip the two 6" DaVinci Shakes may be placed upside down so that the rib structure on the underside is not visible.
- When installing the hip and ridge attempt to nail in areas where the underneath shakes offer support. It is not necessary to nail precisely in the nailing circles. This is especially important on hips. Roofing nails that penetrate through the roof deck by 3/16" should be used.

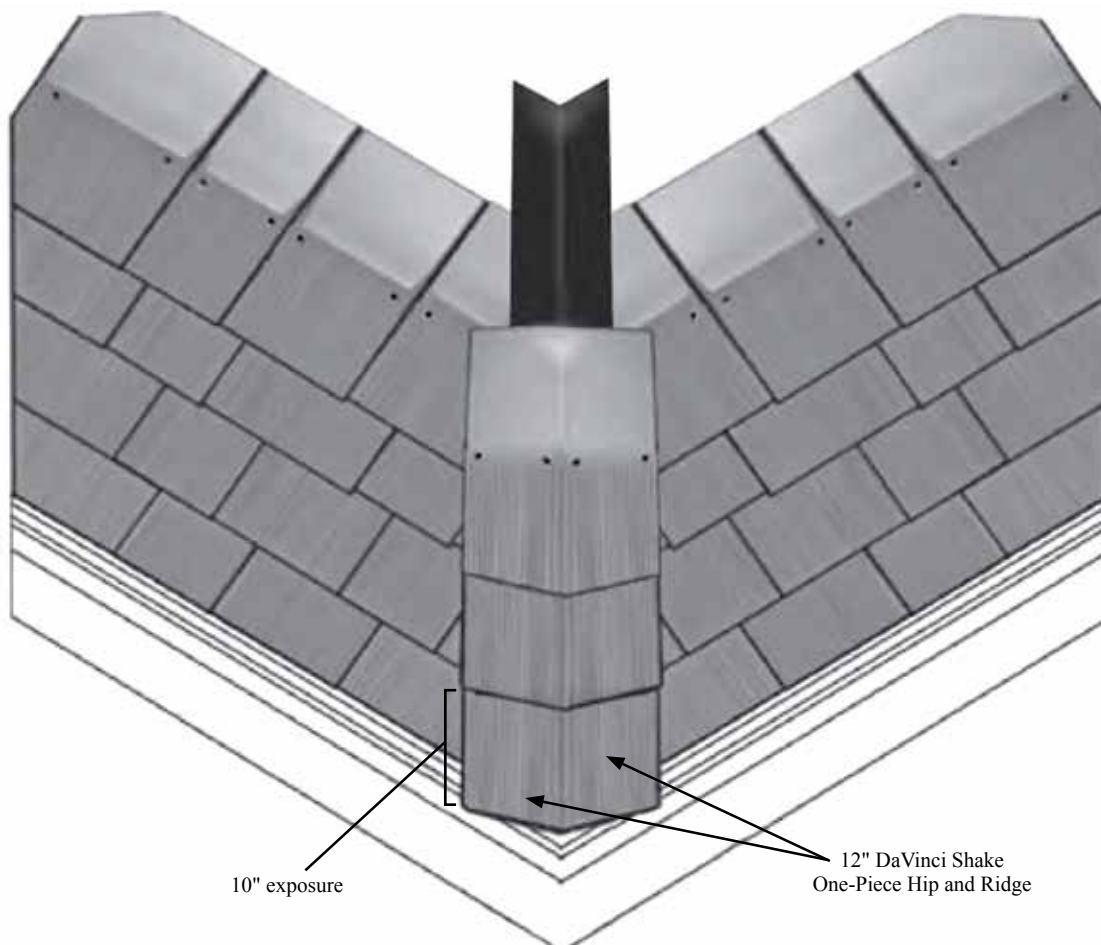

# INSTALLATION

## TWO-PIECE HIP AND RIDGE APPLICATION: HIP AND RIDGE PREPARATION

After installing field shakes, hips and ridges should be prepared by installing a minimum 6" wide piece of non-corrosive metal, UV stable EPDM or equivalent over the hips and ridges. This metal or EPDM should extend at least three inches from the center point on each side of the hip or ridge.

## RIDGE VENT APPLICATION

If using a continuous ridge vent we recommend a rigid shingle roll-over type. When installing continuous ridge vent, care should be taken to insure joints in ridge vent are water tight. Once the continuous vent is installed, prepackaged 6" DaVinci hip and ridge shakes should be installed in accordance with the standard hip and ridge installation instructions below. Caution should be used when cutting the decking on the ridge to assure adequate nailing for the ridge pieces. Roofing nails that penetrate through the roof deck and exceed it by 3/16" should be used.

## TWO-PIECE HIP AND RIDGE SHINGLE APPLICATION

The bottom piece of hip and ridge should be cut so the tip does not extend past the butt of the second course. If preferred on the bottom of a hip, two 6" DaVinci Shake cut 5" wide placed upside down can be used as an under course. This will prevent the rib structure from being seen on the underside. These shakes that make up a hip and ridge unit should be installed with a **ten-inch exposure**. Using a chalk line to assure straightness, the prepackaged 6" hip and ridge should be installed one piece at a time so that the butts of two shingles are adjacent and the inside edges touch.

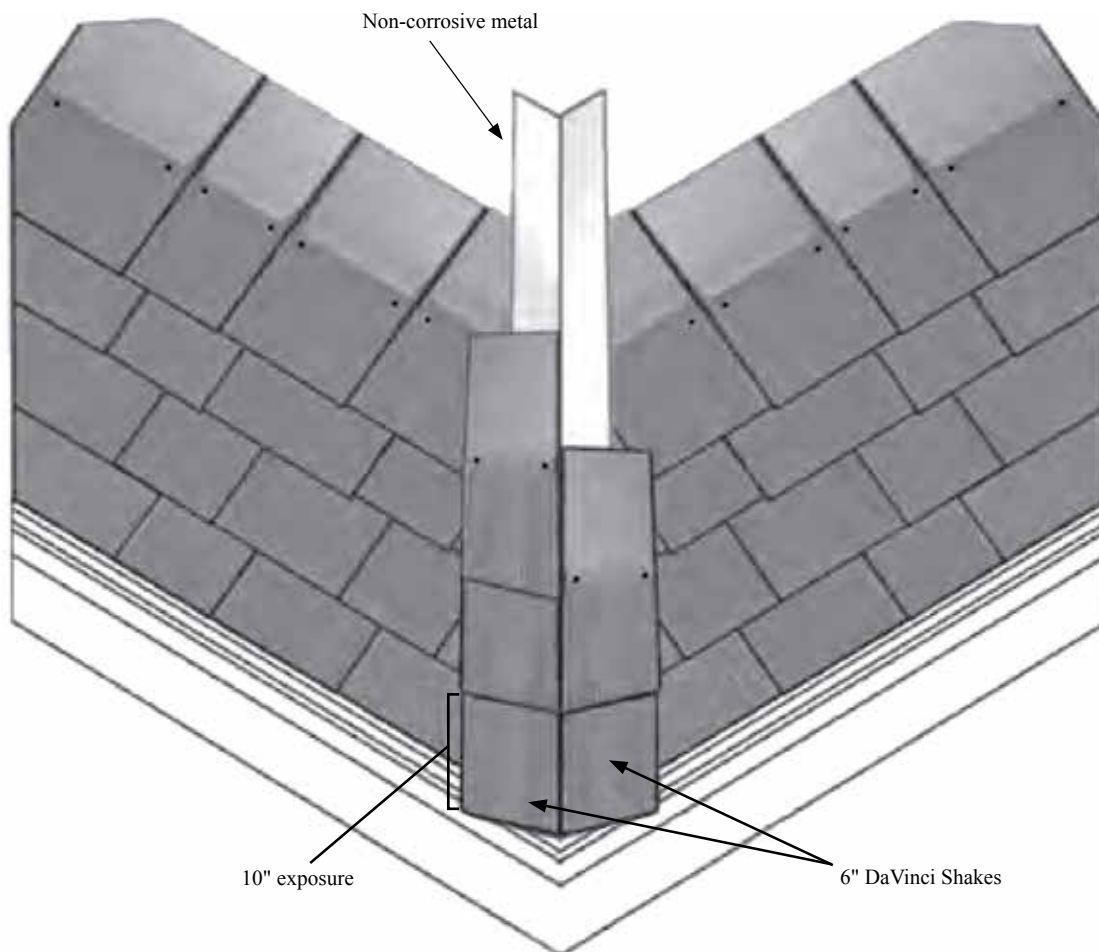

# INSTALLATION

## VALLEYS

Because DaVinci Shake has a rib-structure on the underside\*, care must be used when installing DaVinci Shake in valleys. Open or closed valley systems may be used with variants of each system. Whether installing an open or a closed valley system, valley metal should be made from 24" stock of copper, minimum .019 aluminum, or minimum 28-gauge clad steel. DaVinci requires self-adhered membrane be used in all valleys.

\*A 12" solid shake accessory tile is available.

## OPEN VALLEYS

If open valleys are preferred, be aware that the cut edge of the tile may be seen. Location of the valley, roof pitch and height of roof should be considered in determining if the cut tiles will have an acceptable appearance.

**Option A:** In many cases, with steeper pitched roofs, it is acceptable to install a "W" valley and cut the DaVinci Shake on an angle parallel and 2½" from the center diverter. Keep in mind that the cut rib structure of the shakes may be visible from the ground with some roof pitches.

DaVinci offers 12" solid tiles if the rib structure or open area under DaVinci shakes is a concern.

**Option B:** Double "W" valley. This should be made from 24" stock that is broken in the middle without diverter to look like a "V". Additionally, there should be a "W" (diverter) on either side 2½" from the center line. (See Diagram) DaVinci Shake should be cut and laid against the diverters on either side to mask the rib structure.

**Option A**  
Single Diverter Valley Metal

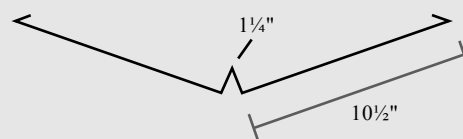

**Option B**  
Twin Diverter Valley Metal

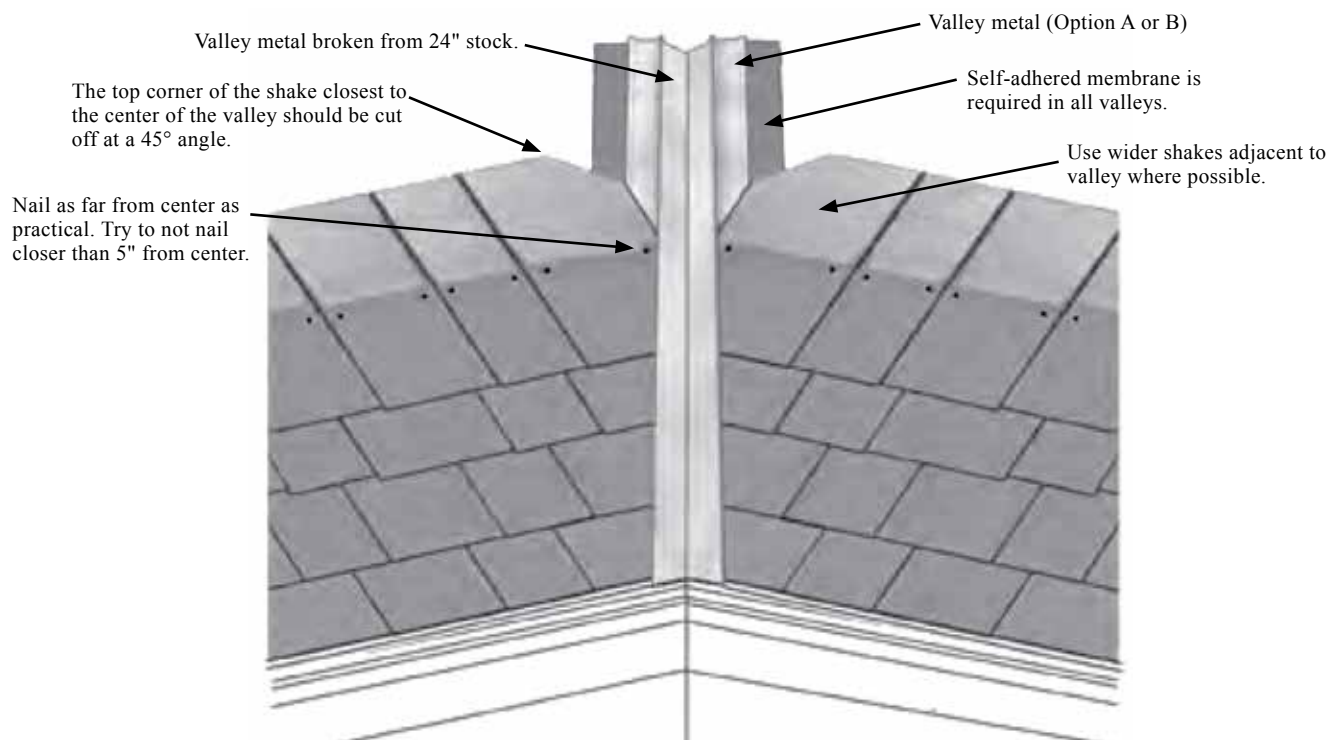
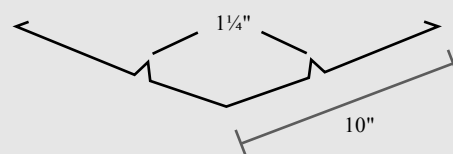

# INSTALLATION

## CLOSED VALLEYS

A closed valley can be achieved by using valley metal option (A or B). In our preferred method, option A, valley metal with a single, narrow-based diverter in the middle is used and the DaVinci Shakes are cut and butted to the diverter. An alternate is to use standard "W" valley with the shakes butted against the diverter. Wider shakes should be used as valley cuts in order to ensure that nailing be kept at least 5" from center or as far from center as possible.

**Option A:** Install valley with a standing seam in the middle and place already-cut DaVinci Shake against center standing seam.

**Option B:** It is acceptable to install a "W" valley and place an all ready-cut DaVinci Shake against center diverter. Metal should be broken with a diverter at least 1 1/4" tall.

**Option A**  
Standing Seam Valley Metal

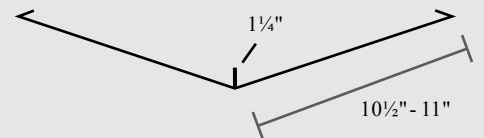

**Option B**  
Single Diverter Valley Metal

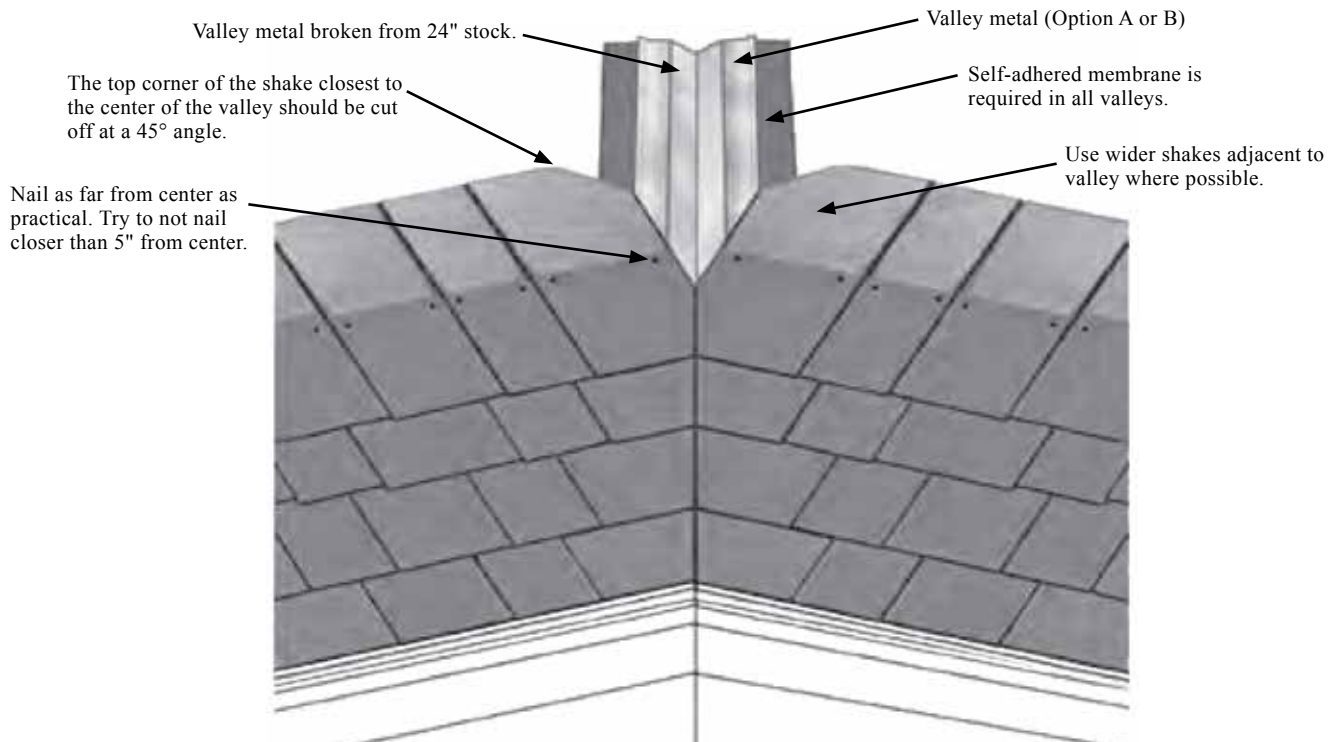
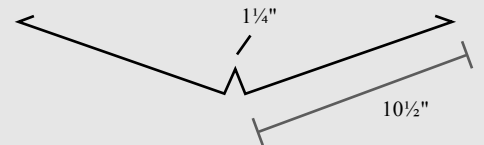



# SPECIAL ISSUES

## FLASHING

Flashing should be used in all areas where the roof abuts a vertical wall, dormer, chimney, skylight or other structural protrusions.

Use the step flashing method, with copper, a minimum of 28-gauge clad steel, or a minimum .019 aluminum flashing. The flashing should extend 4" up vertical walls.

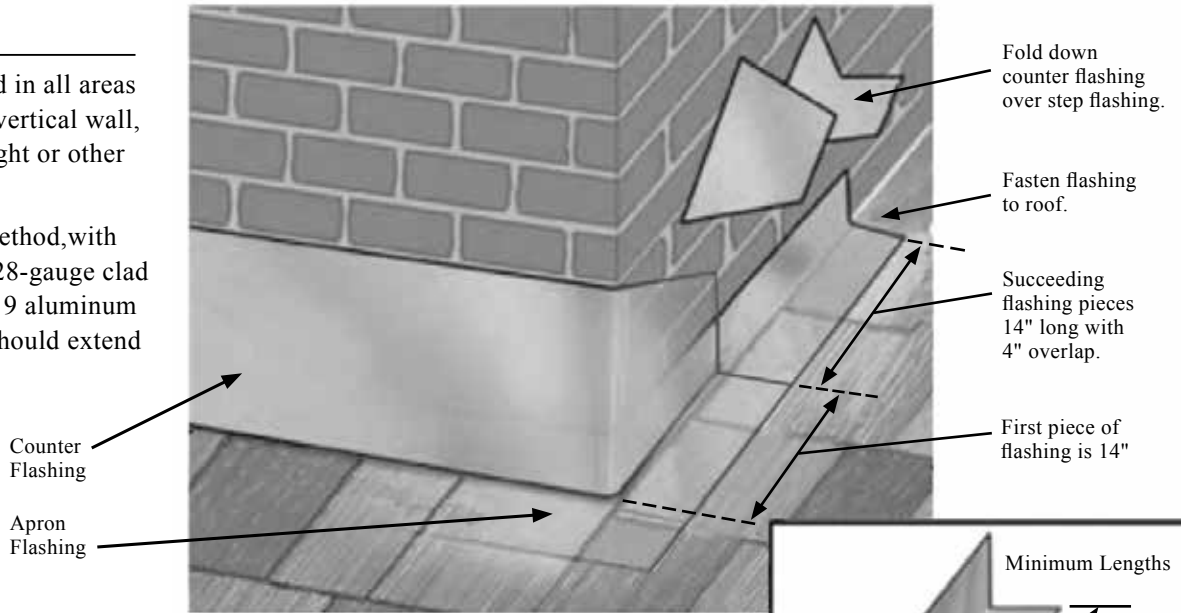

## VENTILATION

In some climatic regions of the country, proper ventilation is crucial to the performance of a roofing system. Proper ventilation is especially important in cold climates where modern houses are well insulated and weather-tight. We suggest you follow standard building practices in your area and meet all national and local building codes. A continuous ridge vent combined with proper intake or eave ventilation is an especially effective ventilation system, and one that we highly recommend.

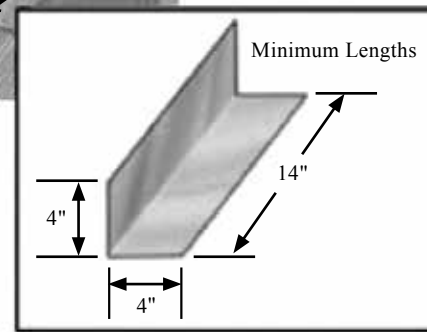

## SNOW GUARDS

Snow guards should be considered in all geographic areas where accumulating snow fall is possible. Most kinds of brass, copper, or clad aluminum snow guard systems work well with DaVinci. Rocky Mountain Snow Guards, Inc. is good source for further information about snow guards. Contact them at [www.rockymountainsnowguards.com](http://www.rockymountainsnowguards.com) or call 877-414-7606. It is recommended that snow guards be installed during the installation of the DaVinci roof although retro-fit snow guards are available for previously installed DaVinci roofs. Details regarding installation remain the responsibility of the installer and the customer.

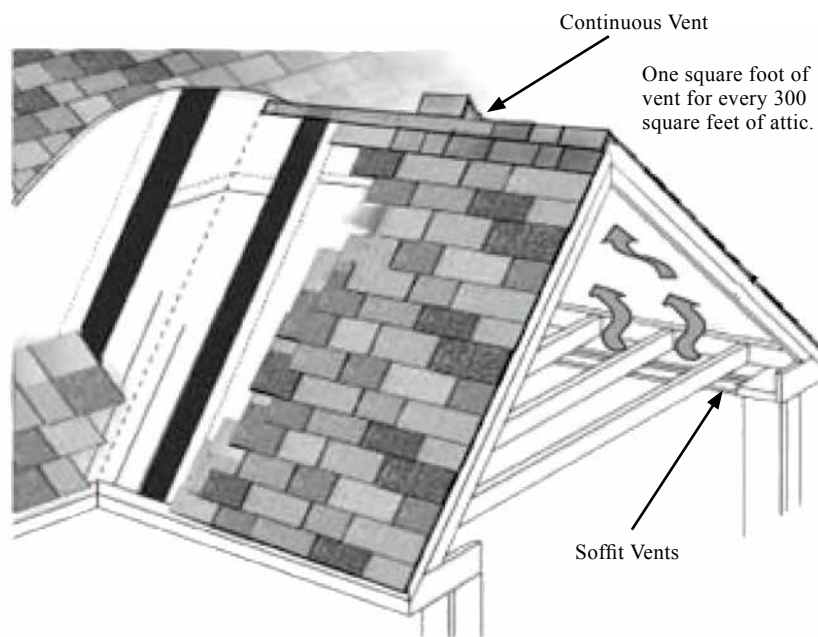

For additional information please see Q & A Guide to Snow Guards at <http://dvroof.com/1BEYN1W>.

**Consult with your local contractor to determine if snow guards would be appropriate for your project. DaVinci makes no representations or warranties about the propriety of snow guard installation on any given project. Rather, the decision to install snow guards rests solely with the end user.**

# PRODUCT FEATURES

## EXPOSURE

| ROOF PITCH      | COURSING        | INTERLAY    | MAX. EXPOSURE |
|-----------------|-----------------|-------------|---------------|
| Less than 3:12  | Not Recommended |             |               |
| less than 6:12  | Staggered       | Required*   | 9"            |
| less than 6:12  | Straight        | Required*   | 10"           |
| 6:12 or greater | Staggered       | Recommended | 9"            |
| 6:12 or greater | Straight        | Recommended | 10"           |

Felt interlay is suggested on any pitch and required on pitches less than 6" in 12".

\*If two layers of Fontana VulcaSeal is used interlay is not required.

## NAILING

Each shake should be applied with two copper, non-corrosive stainless steel, or hot-dipped galvanized, 3/8" head x 1 1/4" length nails in most instances. Roofing nails that penetrate through the roof deck and exceed it by 3/16" should be used. Shakes can be nailed by hand or with a pneumatic nail gun. Don't overdrive nails or drive nails at an angle. Keep the nail head flush with the surface of the shingle to avoid creating "craters" which can collect moisture and can also prevent the exposed end of the shingles from laying flat.

Use these alignment guides with the top edge of the previous row of shakes to control the exposure.

## CUTTING

DaVinci Shake can be cut with a utility knife and straight edge. Electrical circular saws (carbide blade, two teeth per inch) or cordless circular saws (a minimum of 18 volts is recommended) may also be used.

**Please note:** DaVinci Shake is made flat, should be stored flat and must not be installed unless it is flat and in its original form. If shakes are not stored flat and become twisted or curled, lay them flat in a warm place and they will return to their original flatness. Damaged shake should never be installed.

## ELECTRO-GALVANIZED NAILS

DaVinci recommends the use of copper, stainless steel, or hot-dipped galvanized nails. We realize however that in many climatic regions nail corrosion is not a factor in the long-term performance of the roof system. Therefore DaVinci Roofscapes supports the use of Electro-galvanized nails and a system using those nails will be in compliance with the DaVinci Lifetime Limited Material Warranty. The exception to that is that if the nails fail, any portion of the warranty associated with wind performance would be void.



## QUICK REFERENCE

- Don't overdrive or install nails at an angle
- Always leave a gap between all tiles
- Vertical, always install up the roof not one row across the roof at a time
- Install over a clean plywood deck only
- Never use red chalk
- Cut edges always go to the inside along rake edges or gable ends
- Install snowguards in any snow prone area

| ISSUE          | DAVINCI RECOMMENDS            | ACCEPTABLE ALTERNATIVES |
|----------------|-------------------------------|-------------------------|
| Valley         | Copper                        | 28-gauge clad metal     |
| Flashing       | Copper                        | 28-gauge clad metal     |
| Eaves Flashing | Copper                        | 28-gauge clad metal     |
| Nails          | Non-Corrosive Stainless Steel | Hot-dipped Galvanized   |

For questions about DaVinci Shake or its application, contact DaVinci Roofscapes®, LLC  
913-599-0766 or 800-DaVinci (800-328-4624) or [www.davinciroofscapes.com](http://www.davinciroofscapes.com)

*Please be sure to check DaVinci's website for updates. Installation Guide is subject to change without notice.*