



Bellaforté®  
by DAVINCI

# INSTALLATION GUIDE

## SHAKE

Bellaforté Shake is a polymer roof covering carefully engineered to provide the authentic look and durability of its natural counterpart. Special care has been taken to make the product easy to install. By following these instructions and using good installation practices, you will be assured of a quality installation. DaVinci products do not require certified or manufacturer's trained installers. However, a roofing contractor that is well versed in standard roofing installation practices and who has an understanding of DaVinci installation recommendations/requirements, is recommended.



### NOTE TO INSTALLER

Bellaforté Shake has a profile thickness of  $\frac{3}{4}$ " to  $1\frac{1}{2}$ " yet remains lightweight, because the tiles are not solid. When cutting tiles, the ribbed support structure may become visible. In these instances, rake tiles or special flashing detail should be used for the best aesthetic appearance.

Pay special attention to recommendations for accessories, flashings and installation at gable ends (page 7) and valleys (page 6).

**Warning:** *Bellaforté Shake field tiles are not designed to be installed on turrets, domes, or cone-shaped roofing structures. These structures require materials that can be modified to be wider at their base than at their top. Bellaforté's integrated gutter and self-aligning design prevent it from being modified in this way without jeopardizing its ability to shed water properly.*

This information is provided for the use of professional roofing contractors. This Installation Guide does not supersede local building codes which should always be followed. DaVinci Roofscapes® does not warranty or have any responsibility for installation of its products. The DaVinci Roofscapes Lifetime Limited Material Warranty outlines its warranty responsibilities for the roofing materials it manufactures.

For questions about DaVinci Bellaforté or its application, contact Westlake DaVinci Roofscapes®, LLC  
913-599-0766 or 800-DaVinci (800-328-4624) or [www.davinciroofscapes.com](http://www.davinciroofscapes.com)

*Please be sure to check DaVinci's website for updates. Installation Guide is subject to change without notice.*

# INSTALLATION

## DECKING

Bellaforté Shake must be installed on a smooth, flat surface (plywood or OSB); a minimum 15/32" APA approved plywood or 7/16" approved OSB. Imperfections in the decking may transmit through to the finished roof. For this reason, it is recommended that all previous roofing materials be removed prior to installation of Bellaforté Shake. However, there are some circumstances where overlaying one layer of asphalt shingles is acceptable. This is addressed in the Special Issues Section in the back of this guide. Prior to installation over any plank type decking please see the [technical bulletin](#), RE: DaVinci & Installation Over Plank Decking, dated October 24, 2022 for possible concerns or warranty exclusions.

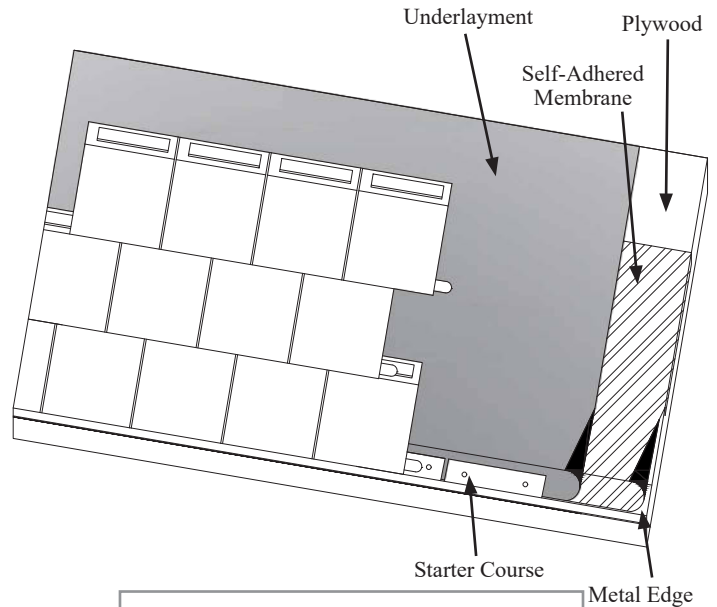

Self-adhered membrane is required on the entire roof deck where the roof pitch is a minimum 3:12 but less than 4:12. Bellaforté may not be installed on roofs with pitches less than 3:12.

## DRIP-EDGE

Metal drip-edge made from copper, aluminum, or coated steel should be installed underneath underlayment on all eaves.

Drip-edge on gable ends is optional when installing rake tiles.

## SELF-ADHERED MEMBRANE

(Severe Climate Underlayment in accordance with Chapter 15 IBC or 9 of the IRC)

A full sheet of self-adhered membrane is required in all valleys. At least 18" of membrane is required on all gable ends, against walls, and around projections.

In areas where the average daily temperature in January is 25° F or lower, or where ice buildup is possible, DaVinci requires self-adhered membrane be installed from the bottom edge extending two feet above the exterior wall line on all eaves.

# UNDERLAYMENT

Roof Pitch	Underlayment
Less Than 3:12	Installation of Bellaforte Not Recommended
*3:12 to 4:12	Self-Adhered Underlayment is Required Over the Entire Deck
Greater Than 4:12	Underlayment as listed per required fire classification or local building code installation specification (Whichever is greater or more stringent)

## CLASS C FIRE RATED SYSTEM:

In addition to self-adhered membrane, a minimum 30 lb. felt that meets ASTM D 226 Type II standard or a listed synthetic underlayment<sup>1</sup> is required over the entire roof.

If self-adhered membrane is required in the field of the roof (if there is a skylight for example), it must be installed so that if water ever lands on it, it will flow on top of the other underlayment, not the plywood.

A proven method of installing the various types of underlayment within a roofing system, which DaVinci recommends, is as follows: Install membrane on the eaves. Cover the membrane and the remaining portions of the roof with the approved underlayment. Then install self-adhered membrane in valleys, along walls and around projections.

# INSTALLATION

## CLASS A FIRE RATED SYSTEM:

In order to meet a Class A system for fire, one layer of Eco Chief Solarhide\* may be installed on the entire roof deck. As an alternative, a minimum of one layer ASTM D 3909 cap sheet<sup>2</sup> and one layer ASTM D 226 type II 30 lb. felt must be installed over the entire deck. These underlayments must be used in addition to the self-adhered membrane in order to fulfill the requirements of a Class A system.

\*This system was approved July 2016 and listed by QAI Laboratories. This system is not yet listed in ESR-2119

**Note 1:** Underlayment and Asphalt Shingles are listed Class A components of a listed roof deck assembly by an Approved Agency. The third party program in which products are certified, carry a label, and are listed in the directory of an agency accredited by the International Accreditation Service, Inc. (IAS), or by an accredited body that is a partner with IAS in a mutual recognition arrangement, pertaining to certification bodies and their compliance with ISO/IEC Guide 65.

General Requirements for Bodies Operating Product Certification Systems. These underlayment and asphalt shingle components are to meet Class A Classification when tested to ASTM E108 or UL 790.

**Note 2:** Underlayment is to be installed with mechanical fasteners in accordance with the manufacturer's published installation instructions. Self-adhering or adhesive applied underlayment and asphalt shingle installations are outside the scope of this listing.

## NAILS

Tiles should be installed with nails long enough that they will penetrate through the roof deck and exceed it by 3/16". In most instances 1 3/4" roofing nails are acceptable. Minimum 3/8" head is required. We recommend gun driven ring-shank hot-dipped galvanized nails. Copper and stainless steel nails may also be used and are recommended when they come in contact with copper flashing to prevent galvanic action. Ring-shank nails are optional for plywood, but must be used for OSB decks and in high wind areas. Each Bellaforté tile should be fastened with a minimum of two nails, one in the tab and one in the top right corner. Some circumstances or codes require three to five nails.

## STARTER COURSE

It is imperative that the starter course be straight or subsequent courses will not align properly. The Bellaforté field tiles rely on the starter course to maintain straight coursing. It is therefore necessary that there be a chalk line laid to assure that the starter is straight. For a Shake installation, the chalk line should be snapped approximately 2 1/2" above the bottom edge of the roof. The starter tiles should be placed so the top edge of the starter tile is placed on the line. The amount of overhang may be adjusted as needed to achieve the best water flow into the gutter. The starter tiles must be spaced 3/8"- 1/2" apart as tiles will expand and contract with temperature change. Buckling of the starter pieces may occur if the starter pieces are not spaced properly.

***Only white or blue chalk should be used on Bellaforté roofs, as permanent chalk (red or orange) will stain the tiles permanently.***

## FIELD TILE (For wind speed warranty in excess of 90 mph (110 mph) see high wind installation guidelines under special issues.)

The Bellaforté Shake field tiles must be laid from left to right. The outside edge of the tile will be covered by a rake tile on a gable end or a hip and ridge tile on a hip so precise cutting is not necessary. For installing Bellaforté Shake without a rake tile, please see Rake Tile Section prior to installing any field tile.

The first tile should seat directly on the starter tile. The stop or ledge on the bottom of the field tile rests directly on top of the starter. Slide the tile so the gutter and overlock line up approximately in the middle and are not laid tightly. The field tile should then be nailed on the tab first and then on the right hand side of the previous tile.

Once the first tile is in place, a tile should be placed on top of it to start the second course. This tile should be placed so that it nests on top of the first tile with the ledge on back resting on the top of the first course tile. Slide the tile to the left so that the right side edges of the two tiles are offset by a minimum 3". Before nailing, the overhanging portion on the left side of the tile should be removed. The cut tile should be installed with two nails, one on the tab and another in the top left corner. Then the second tile of the bottom course should be installed.

# INSTALLATION

The installation should continue so that the gutter of this next tile is placed under the right side of first tile and is sitting on the ledge of the starter or tile below. You should not push the tiles together tightly. When the tile is properly in place, it should feel locked in place when **pulled down and to the right**. The installation should continue in this manner. Tiles should be installed in a stair step manner and several courses should be installed going across the roof at one time to assure good color blending. Care should be taken to minimize false breaks from lining up to assure the most realistic appearance.

**Note:** tiles may also be nailed on the top left but this is not required for wind performance in non HVWZ areas.

A random pattern is the simplest pattern and one that is aesthetically pleasing to many. This pattern is accomplished by setting the shingles back random amounts as long as there is a minimum 3" side-lap from the gutter of one tile to the gutter on the tile that sits on the course above or below it. A random pattern is forgiving in that the vertical pattern alignment does not need to be constantly checked to make sure it is straight.

When installing Bellaforté tiles, a horizontal line should be chalked occasionally to assure horizontal alignment. If tiles must be adjusted to assure straightness the adjustment should be taken out over several courses. Standard Bellaforté Field Tiles cannot be lowered because of the stop mechanism and can only be raised a maximum of 1/4" per course. Bellaforté transition tiles can be used to lower a course if required. These tiles are standard field tiles that have had the portion of the ledge that provides a stop, removed at the factory. One of the reasons these tiles were designed was to provide adjustment options as needed. If the lowering of courses is required and transition tiles are not available, they can be made onsite from existing standard field tiles. This can be done by removing the ledge from the sides and bottom of a standard tile, so that it is able to lay flat as it is lowered onto the course below.

Alternate pattern methods may be used. Instead of a random pattern, the Bellaforté Shake may be set back in a repeating four course pattern. The first course is a full piece of field with the water channel or gutter removed. The second course is cut at approximately the B in the word Bellaforté, located in the upper left hand side of each tile. The third course is a full piece of field with the water channel removed and is the same as the first course. The fourth course is cut at the last E in the word Bellaforté. Care should be taken to not have a "B" and "E" cut together without a full course in between as the offset will be too close together. This is an efficient method of setting your offset so that it minimizes the false breaks from lining up in the field.

**Chalk lines should be snapped on the underlayment only. Do not snap chalk lines on the visible portion of any DaVinci products. Red and orange permanent chalk will permanently stain DaVinci tiles.**

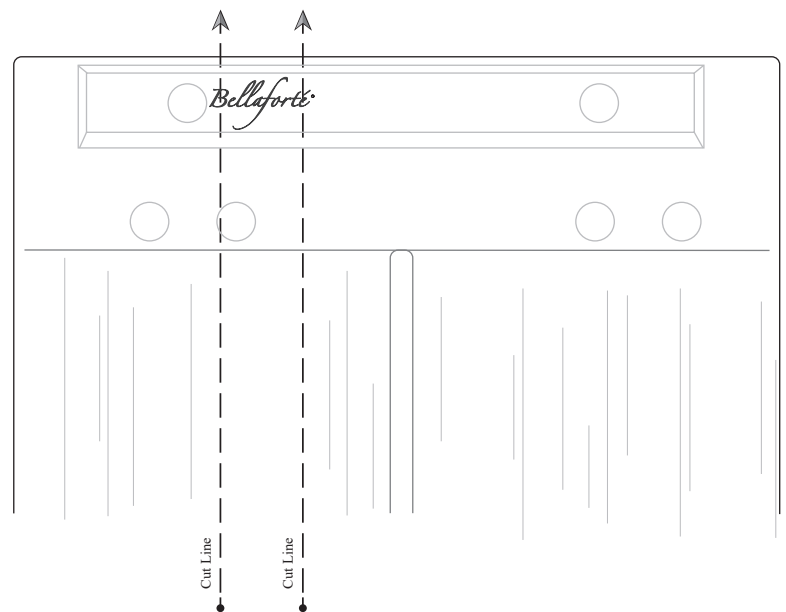
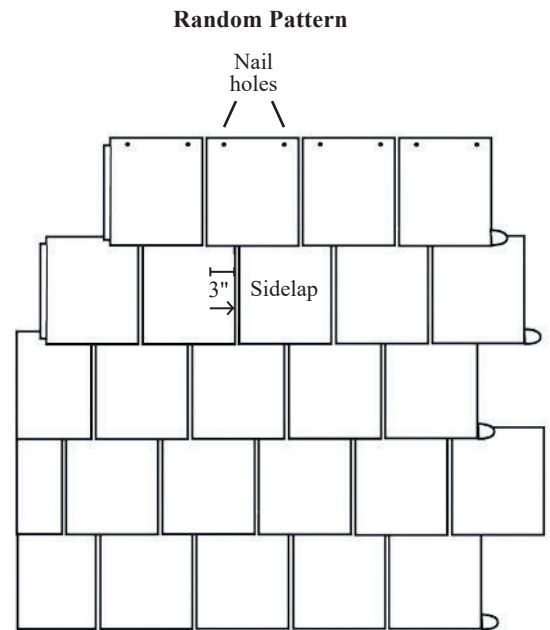

# INSTALLATION

## FLASHING

---

Flashing should be used in all areas in which the roof abuts a vertical wall, dormer, chimney, skylight or other structural protrusions. The use of copper, a minimum 28-gauge clad steel or a minimum .019 aluminum is acceptable.

### PAN FLASHING METHOD

---

Walls or projections must be prepared by installing a minimum of 18" self-adhered membrane that turns up the wall at least 4" and back on the deck (underlayment) at least 14". With the self-adhered membrane in place, a 6" x 4" piece of "L" metal should be installed so that 4" goes up the wall and 6" lies on the roof deck. An additional strip of membrane should be placed on top of the "L" metal and onto the underlayment if there is not a return on the outside edge of the pan metal. If the abutment terminates in the "field," the membrane must go over the top of the "field" underlayment. The roof edge of the metal should be crimped. This metal should extend on top of the field tile below. When installing the first tile on the flashing, a Bellaforté transition tile should be used.

### STEP FLASHING METHOD

(Requires Transition Tiles)

Walls or projections must be prepared by installing a minimum of 18" self-adhered membrane that turns up the wall at least 4" and back on the deck (underlayment) at least 14". For the termination of each course, a transition tile must be installed with a piece of step flashing 4" x 6" x 14" that has two water diverters 1/8" tall formed into the flashing. DaVinci Roofscapes has stepflashing like this available. The step flashing will be installed under each transition tile and held in place by the nail that each tile receives at the top.

*Note: Step flashing may also be fabricated in the field by taking a flat piece of 4"x 6"x 14" step flashing and bending a 1/4" return on the edge of the deck-side of the flashing. The ribs on the underside of the tile will need to be removed to accommodate the return on the flashing.*

### TRANSITION TILES

---

The Bellaforté transition tile is a tile without the alignment ledge on the back. Transition tiles are used wherever there is a metal flashing that occurs between courses. Examples of this include pipe flashings, valleys that terminate in the field and step flashings. Transition tiles may also be used wherever toe-irons are used to support walk boards. Transition tiles are also used to adjust coursing when necessary. Once the first transition tile makes the transition, subsequent tiles may be regular Bellaforté field tiles. A transition tile may be fabricated in the field by removing the back ledge with a knife or planer. Unused transition tiles may be substituted for regular field tiles but a chalk line must be used to maintain straight coursing.

### VALLEYS

---

Bellaforté Shake may be installed as an open or closed valley. For a closed valley, "W" valley metal should be used. The center diverter should be a minimum 1 3/4" for Shake. For an open valley, the valley metal should be broken in the middle with diverters on either side. These diverters also need to be a minimum 1 3/4". With the valley metal in place, an 18" strip of self-adhered membrane should be placed on top of the valley metal. The membrane should be parallel and 1" from the diverter and should extend past the outside edge of the valley. Cut Bellaforté tiles should not be laid tightly against any flashing or valley metal. A minimum continuous and uniform space of 1/8" is best. IT IS REQUIRED THAT THE TOP CORNER OF THE TILE THAT IS CLOSEST TO THE CENTER OF THE VALLEY BE CUT ON AN ANGLE TO PREVENT WATER FROM HITTING THE CORNER AND TRAVELING HORIZONTALLY.

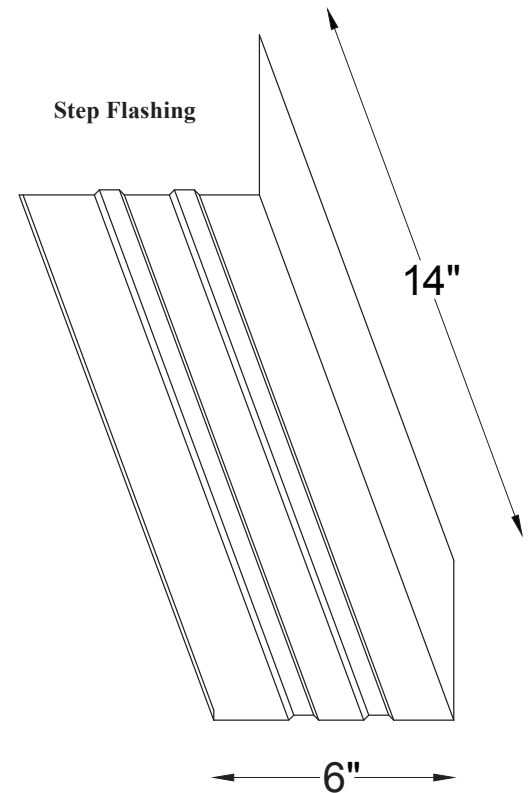
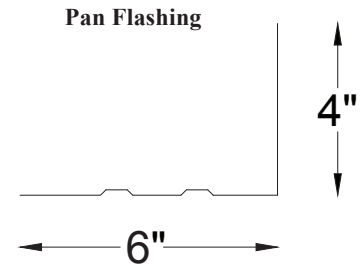

# INSTALLATION

## VALLEYS

When nailing a piece of tile in the valley that is 6" or shorter, it is recommended that one fastener be placed in the upper corner where the cut tile overlaps. Fasteners need to be placed as far from the diverters as possible without regard to nail placement marks on the tiles. If very narrow pieces are needed in the center of the valley, for aesthetics, they should not be nailed but wired or clipped to the adjacent field piece that is mechanically fastened.

### DaVinci Valley Metal Options

- All metal valleys to be manufactured using 2' wide panels at a minimum.
- All returns are to be ½"
- All Bellaforté Shake Diverters minimum 1¾"

### Open Valley Appearance Options

**Open Valley Metal, Single Open, or Closed Diverter Metal:** In many cases, with steeper pitched roofs, it is acceptable to install open valley metal or either type of single diverter valley metal and cut the Bellaforté tile on an angle parallel and 2½" from the center or center diverter. Keep in mind that the cut rib structure of the tiles may be visible from the ground with some roof pitches.

**Twin Diverter Open or Closed:** Double open or double closed diverter metal can be used to provide an open valley appearance while also blocking the support ribs on the underside of cut tiles. This should be made from 24" stock that is broken in the middle without diverter to look like a "V". Additionally, there should be a closed or open diverter on either side of the center line. Bellaforté should be cut and laid against the diverters on either side to mask the rib structure. This option will leave a visible portion of metal centered on the valley commonly 5-7" wide.

### Closed Valley Appearance Options

**Single Open or Closed Diverter:** In many cases, with steeper pitched roofs, it is acceptable to install a single open or closed diverter valley. The Bellaforté Shake tiles are then cut appropriately in order to lay near the center diverter. This option will only leave a small seam or crown of the diverter visible and resembles a closed valley.

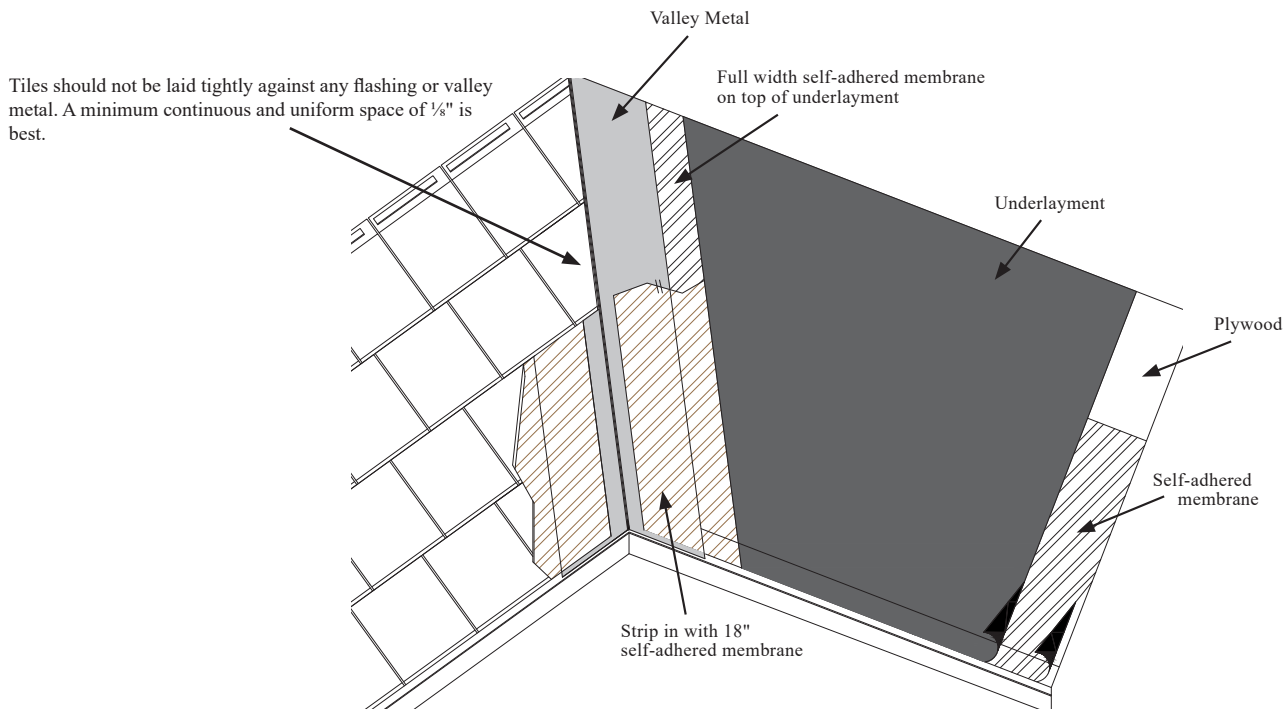
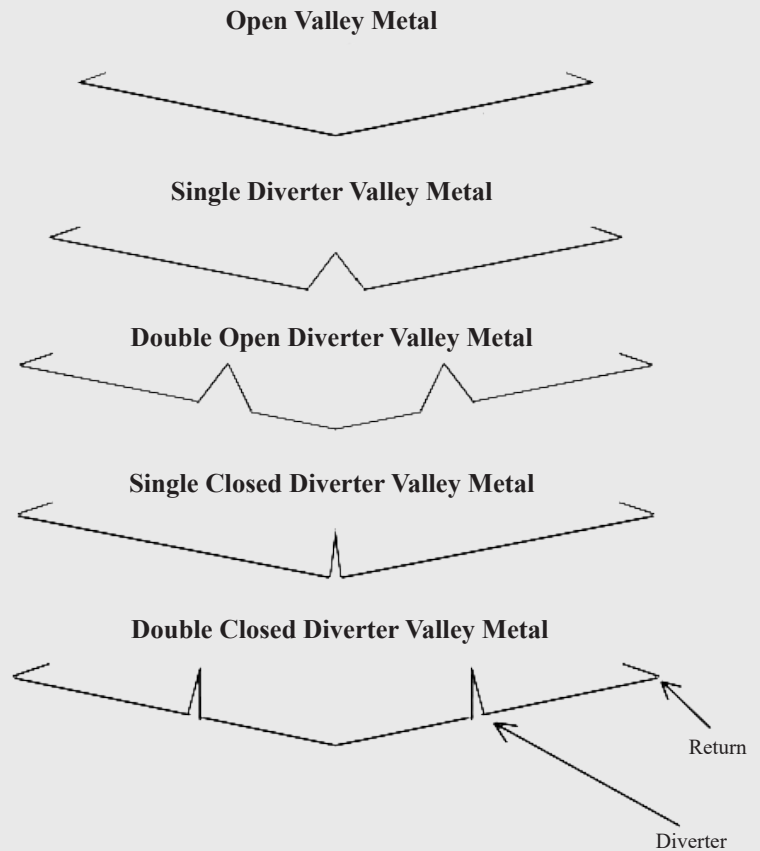

# INSTALLATION

## RAKE TILE – BELLAFORTÉ SHAKE

An 18" strip of self-adhered membrane should be installed vertically on top of the underlayment on gable ends so that  $\frac{3}{4}$ " of the membrane overhangs the gable end and is bent down over the rake edge. Bellaforté tiles placed on the gable end may be nailed anywhere that they will be covered by the rake tile.

### Method 1: Rake Tiles

Install the 12" field tiles without false breaks to begin and end each course on gable ends. This makes the thickness of the tiles on the gable ends consistent. Once all the field tiles have been installed the first rake tile is installed, with the thicker end down, on the gable end so that the butt of the tile is flush with the butt of the bottom course of field tiles. The tip of the first rake tile should be cut so that it doesn't

overlap the second course of tile. The rake tile should be nailed once on the roof side and once on the wall side. The tile should be nailed high enough so that the nails are covered by the next rake tile. The second rake tile should be installed so that the tip of the rake tile just touches the butt of the second course and placed with the thicker side up as it is the nominal thickness of the course of field tile. Subsequent rake tiles should be installed in the same way. An additional color matching screw is recommended when there is unevenness in the appearance or in high wind areas. The screw should be placed 3" from the bottom of the rake and screwed into the rake fascia.

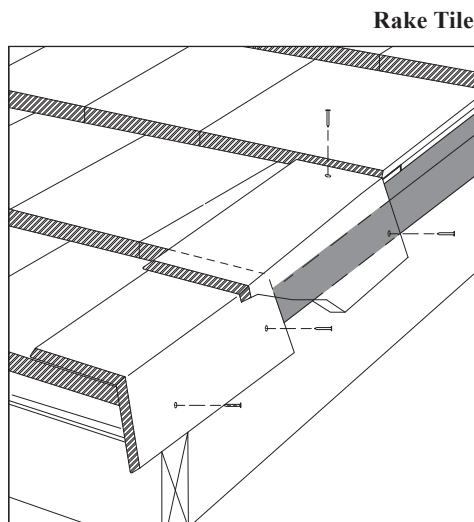

Rake Tile

Rake Tile Cross Section

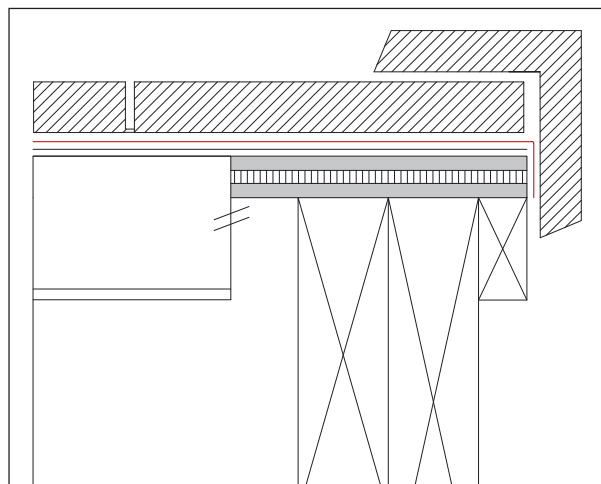

Metal Rake Edge

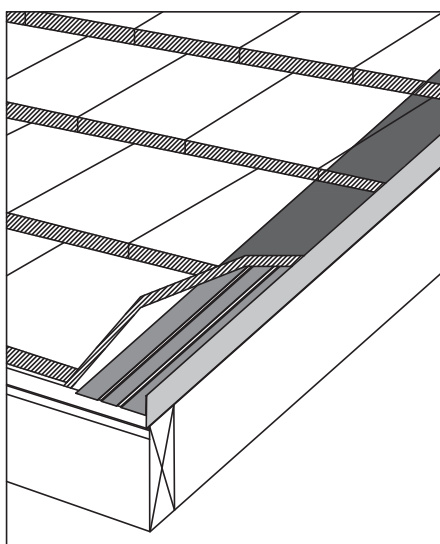

Metal Rake Edge

Rake J Channel

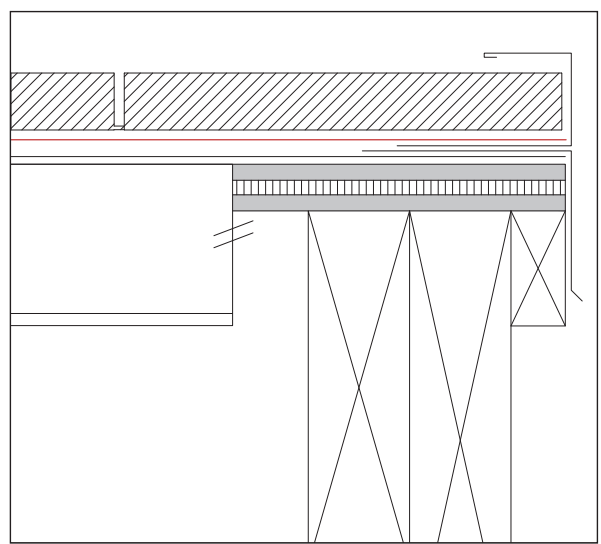

### Method 2: Metal Rake Edge

Gable End/Rake installation without rake tiles. A piece of flashing can be installed to terminate the tiles at the gable ends. The rake metal trim looks like a "T" with the main leg 4" and  $1\frac{1}{2}$ " on each side of the top of the "T". Once the metal trim has been installed, a 12" wide strip of self-adhered membrane should be installed on top of the metal trim so that at least  $2\frac{1}{2}$ " of the 4" leg is covered. The Bellaforté Shake field tiles are then cut and applied tight against the  $1\frac{1}{2}$ " rise of the rake metal.

### Method 3: Gable End/Rake with J channel 2-piece method

A piece of 90-degree drip-edge can be installed at the end of the roof deck over the underlayment and down the rake fascia board. A piece of  $1\frac{1}{2}$ " J channel can then be added flush with the drip-edge and stripped in with a peel and stick underlayment. The field tiles are then placed into the J channel slot.

# INSTALLATION

## CUTTING

A cordless battery operated circular saw is recommended for efficient cutting of Bellaforté tiles. A standard wood cutting blade is adequate for smooth cuts. A razor knife can be used to cut the tiles, although it is more difficult and time consuming, and results in an uneven cut edge.

## HIP AND RIDGE TILE

The one piece hip and ridge tile should be installed at a 12" exposure (unless the pitch of the roof is greater than 12/12. When installing on roofs with pitches greater than 12/12 tiles may need to be installed at a 10" exposure or less) in order to provide a more flat and uniform appearance. All one piece hip and ridge should be formed to the pitch of the roof prior to install. The tiles should be nailed once on each side about  $\frac{3}{4}$ " from the outside edge with an approved fastener long enough to penetrate through the roof deck and exceed it by  $\frac{3}{16}$ ". (2½" roofing nails are acceptable in most instances.) The hip and ridge should be nailed approximately 12½" from the butt of the tile, and  $\frac{1}{2}$ " to  $\frac{3}{4}$ " inch from the outside edge. When nailing tiles along a hip, avoid placing fasteners in an area that causes the tiles to distort or dip. Many times this can be avoided by placing the fastener an inch above the original fastening location. If the tile must be nailed in the gap below the butt of the field tile, don't drive the nail down so hard that it distorts the hip and ridge tile. A chalk line should be used on the hips to assure straightness. A shingle over type continuous ridge vent may be used if wanted. If continuous ridge vent is used, nails used to secure the hip and ridge tiles must penetrate through the decking and exceed it by  $\frac{3}{16}$ ".

### Hip Starter Application:

At the bottom of a hip, the hip and ridge tile may be cut on an angle so that the bottom edge may be installed parallel with the eave. A piece of flashing or UV stable roofing material should be installed along the bottom 6" of the hip in order to protect the area under the seam formed by the cut material. The cut hip and ridge tile is then assembled so that the two cut pieces are butted together to form the bottom piece of hip and ridge. Once these two tiles are in place, a full hip and ridge tile is installed and pulled down so the outside corners just reach the bottom of the roof.

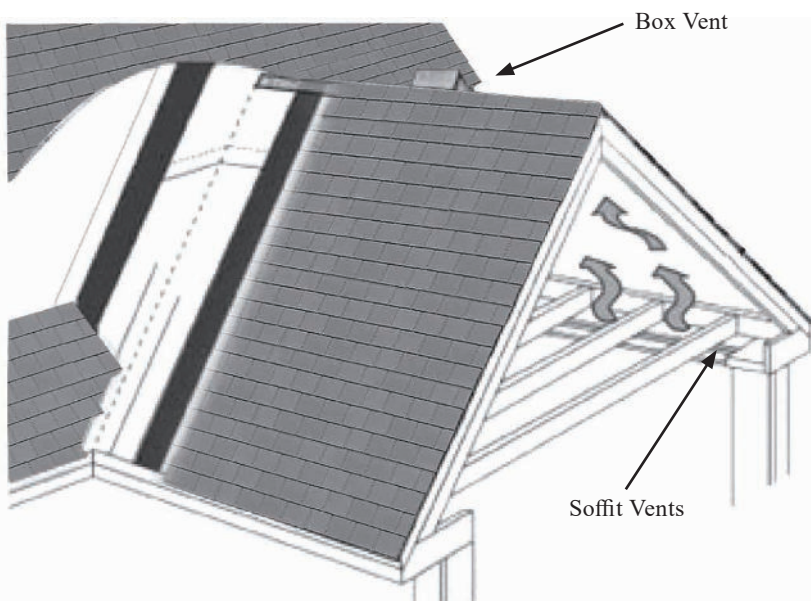
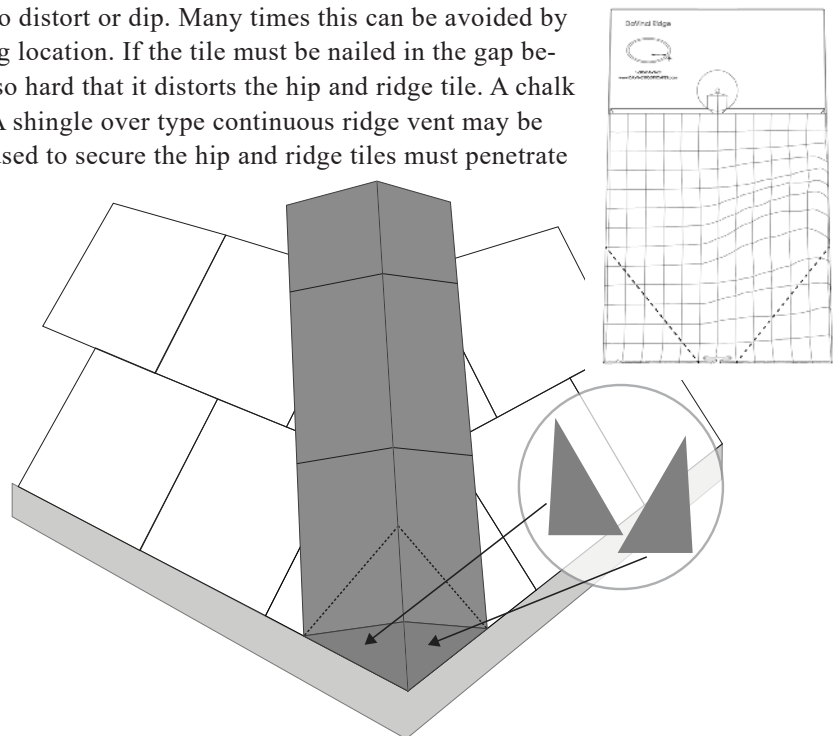

## VENTILATION

Adequate ventilation is crucial to the proper performance of a roofing system. Adequate ventilation is especially important in cold climates where modern houses are well insulated and weather-tight. We suggest you follow standard building practices in your area and meet all national and local building codes. A continuous ridge vent combined with appropriate soffit ventilation is an especially effective ventilation system that we recommend.



# SPECIAL ISSUES

## SNOW GUARDS

---

Snow guards should be considered in all geographic areas where accumulating snowfall is possible, since snow can slide off polymer and other roofing materials easily. Most kinds of brass, copper, or clad aluminum snow guard systems work well with DaVinci. Rocky Mountain Snow Guards, Inc. is a good source for further information about snow guards. Contact them at [www.rockymountainsnowguards.com](http://www.rockymountainsnowguards.com) or call 877-414-7606. It is recommended that snow guards be installed during the installation of the DaVinci roof, although retro-fit snow guards are available for previously installed DaVinci roofs. Details regarding installation remain the responsibility of the installer and the customer.

For additional information, please see Q & A Guide to Snow Guards at <http://dvroof.com/1BEYN1W>.

**Consult with your local contractor to determine if snow guards would be appropriate for your project. DaVinci makes no representations or warranties about the propriety of snow guard installation on any given project. Rather, the decision to install snow guards rests solely with the end user.**

## HIGH WIND AREAS (Additional installation requirements for upgraded 110 mph wind warranty)

---

- 1.75" Hot Dipped, Ring Shank Nails are required for High Wind applications
- Bellaforté requires five (5) fasteners for "High Wind" applications. One nail must be placed in each of the (4) pre-marked circles below the upper trough and one in the lower right tab as indicated in the instructions.
- All One-Piece Hip & Ridge applies at 10" exposure rather than standard 12". (Approx 18% more H&R needed)
- All Rake pieces need to be face fastened at the butt end into the fascia with exposed screws.
- For Florida or HVHZ areas, refer to local building codes. Miami Dade NOA # 14-0922.02

## ASPHALT SHINGLE OVERLAY INSTALLATION

---

Although it is recommended that Bellaforté be installed on a smooth, flat surface where all previous roofing material has been removed, overlaying one layer of Class A fiberglass asphalt shingles is an acceptable alternative. In some situations, when performing a roof over installation the following items must be addressed in addition to the standard installation method. Also, nothing written here is meant to supersede any local and/or national building codes which must always be followed and should be researched prior to any job start.

### Preparation:

The new roof may show any imperfections that are in the existing substrate as unpleasant dips and bumps. This can be minimized by cutting and/or fastening all buckled, raised, and curling shingles. The surface should be as flat and smooth as possible.

Shingles along the eaves and rakes must be cut back in order to install the starter and rake tiles.

### Fasteners:

Nails for field tiles should be long enough to penetrate the roof deck and exceed it by a minimum 3/16". Nails used for hip and ridge should also penetrate the roof deck and exceed it by 3/16".

### Rake Edges/Gable Ends:

A piece of "L" shaped drip edge may need to be used along rake/gable ends, depending on the thickness of the existing shingle roof. This would be installed on top of the existing shingles along the rakes and under the new field tiles. The metal should be bent in such a way that it has a minimum of 3" on the roof deck side and an appropriate length of metal to overlap the corresponding rake fascia board by a minimum of 1/2". The rake tiles would then be installed as previously instructed. The purpose of the metal is to close and protect any opening that would have been present between the bottom of the installed rake tiles and the existing rake trim or shingle molding.

### Flashings:

All flashings must be new and cannot just be caulked, cemented, or resealed. This includes, but is not limited to, valleys, step, pipe, vent, etc.

# SPECIAL ISSUES

## NAILING

Each Tile must be installed with a minimum of two hot-dipped galvanized nails (An additional nail on top is optional). Roofing nails that penetrate through the roof deck and exceed it by 3/16" must be used. Tiles can be nailed by hand or with a pneumatic nail gun. Don't overdrive nails or drive nails at an angle. Keep the nail head flush with the surface of the shingle to avoid creating "craters" which can collect moisture and can also prevent the exposed end of the shingles from lying flat.

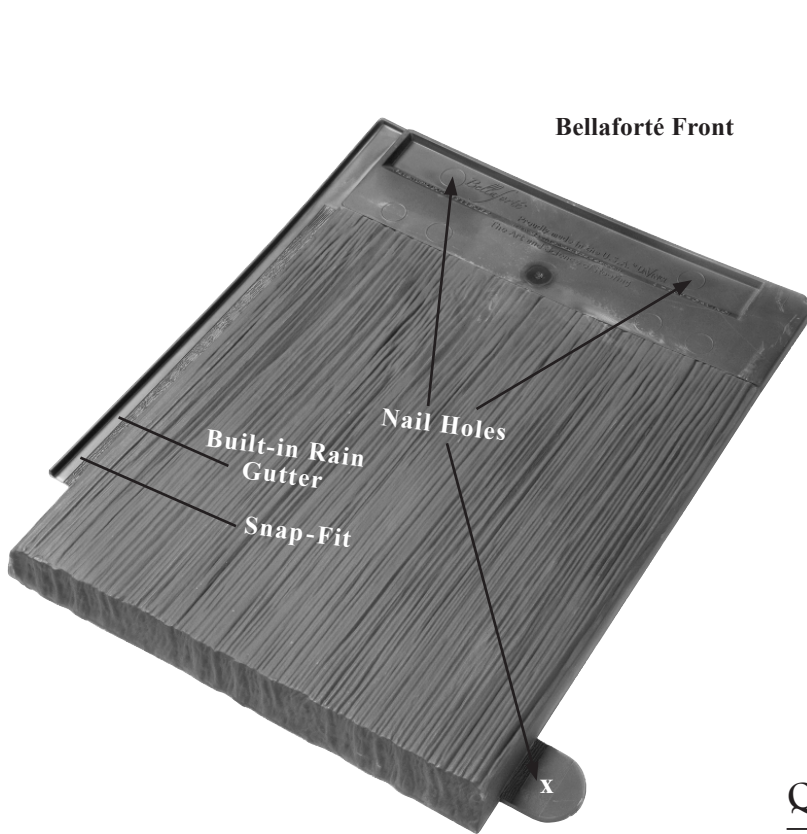

## ELECTRO-GALVINIZED NAILS

DaVinci recommends the use of hot-dipped galvanized, copper, or stainless steel nails. We realize however that in many climatic regions, nail corrosion is not a factor in the long-term performance of the roof system. Therefore, DaVinci Roofscapes supports the use of Electro-galvanized nails and a system using those nails will be in compliance with the DaVinci Lifetime Limited Material Warranty. **Exception:** If the nails fail, any portion of the warranty associated with wind performance would be void.

## Repair

Anytime Bellaforté tiles are removed or adjusted and reused, all previous fastening points must be filled with a new fastener or compatible sealant. All previous fastening points are required to be occupied. If a sealant is used and the adhesion or sealant fails this is not covered under the Davinci Lifetime Limited Material Warranty.

For questions about DaVinci Bellaforté or its application, contact Westlake DaVinci Roofscapes,® LLC  
**913-599-0766 or 800-DaVinci (800-328-4624) or [www.davinciroofscapes.com](http://www.davinciroofscapes.com)**

*Please be sure to check DaVinci's website for updates. Installation Guide is subject to change without notice.*

## QUICK REFERENCE

ISSUE	DAVINCI RECOMMENDS	ACCEPTABLE ALTERNATIVES
Valley	28-Guage Clad Metal	Copper or Aluminum
Flashing	28-Guage Clad Metal	Copper or Aluminum
Eaves Flashing	28-Guage Clad Metal	Copper or Aluminum
Nails	Hot-dipped Galvanized	Stainless Steel or Copper